

# Sonde DP

Sonde di temperatura e umidità

*Temperature and humidity sensors*

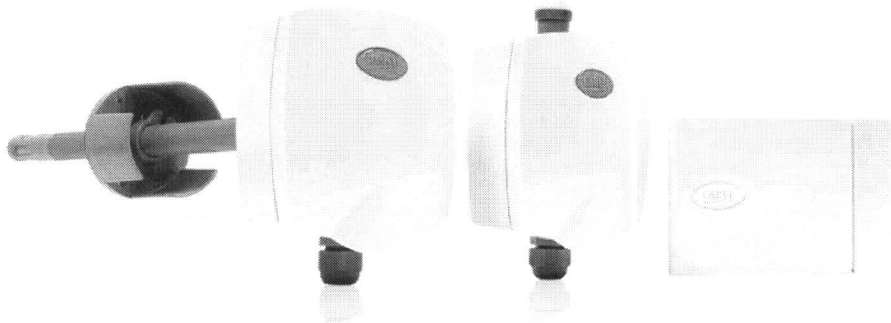

Manuale d'uso



User manual

**LEGGI E CONSERVA  
QUESTE ISTRUZIONI** ←  
**READ AND SAVE  
THESE INSTRUCTIONS**



# User manual

## WARNINGS



CAREL bases the development of its products on decades of experience in HVAC, on the continuous investments in technological innovations to products, procedures and strict quality processes with in-circuit and functional testing on 100% of its products, and on the most innovative production technology available on the market. CAREL and its subsidiaries/affiliates nonetheless cannot guarantee that all the aspects of the product and the software included with the product respond to the requirements of the final application, despite the product being developed according to start-of-the-art techniques. The customer (manufacturer, developer or installer of the final equipment) accepts all liability and risk relating to the configuration of the product in order to reach the expected results in relation to the specific final installation and/or equipment. CAREL may, based on specific agreements, act as a consultant for the positive commissioning of the final unit/application, however in no case does it accept liability for the correct operation of the final equipment/system. The CAREL product is a state-of-the-art product, whose operation is specified in the technical documentation supplied with the product or can be downloaded, even prior to purchase, from the website [www.carel.com](http://www.carel.com).

Each CAREL product, in relation to its advanced level of technology, requires setup/configuration/programming/commissioning to be able to operate in the best possible way for the specific application. The failure to complete such operations, which are required/indicated in the user manual, may cause the final product to malfunction; CAREL accepts no liability in such cases.

Only qualified personnel may install or carry out technical service on the product. The customer must only use the product in the manner described in the documentation relating to the product.

In addition to observing any further warnings described in this manual, the following warnings must be heeded for all CAREL products:

- Prevent the electronic circuits from getting wet. Rain, humidity and all types of liquids or condensate contain corrosive minerals that may damage the electronic circuits. In any case, the product should be used or stored in environments that comply with the temperature and humidity limits specified in the manual.
- Do not install the device in particularly hot environments. Too high temperatures may reduce the life of electronic devices, damage them and deform or melt the plastic parts. In any case, the product should be used or stored in environments that comply with the temperature and humidity limits specified in the manual.
- Do not attempt to open the device in any way other than described in the manual.
- Do not drop, hit or shake the device, as the internal circuits and mechanisms may be irreparably damaged.
- Do not use corrosive chemicals, solvents or aggressive detergents to clean the device.
- Do not use the product for applications other than those specified in the technical manual.

All of the above suggestions likewise apply to the controllers, serial boards, programming keys or any other accessory in the CAREL product portfolio.

CAREL adopts a policy of continual development. Consequently, CAREL reserves the right to make changes and improvements to any product described in this document without prior warning.

The technical specifications shown in the manual may be changed without prior warning.

The liability of CAREL in relation to its products is specified in the CAREL general contract conditions, available on the website [www.carel.com](http://www.carel.com) and/or by specific agreements with customers; specifically, to the extent where allowed by applicable legislation, in no case will CAREL, its employees or subsidiaries be liable for any lost earnings or sales, losses of data and information, costs of replacement goods or services, damage to things or people, downtime or any direct, indirect, incidental, actual, punitive, exemplary, special or consequential damage of any kind whatsoever, whether contractual, extra-contractual or due to negligence, or any other liabilities deriving from the installation, use or impossibility to use the product, even if CAREL or its subsidiaries are warned of the possibility of such damage.

## DISPOSAL

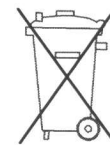

### Disposal of the product

The appliance (or product) must be disposed of separately in compliance with the local standards in force on waste disposal.

Contents

- 1. Introduction..... 35
  - 1.1 General features..... 35
- 2. CAREL coding ..... 36
- 3. Codes and compatibility with the AS\* series..... 37
- 4. Installation ..... 39
  - 4.1 Connections for sensors with analogue output..... 39
  - 4.2 Connections for sensors with RS485 serial output..... 41
  - 4.3 Example of configuring the RS485 serial sensor..... 41
  - 4.4 Example of connection to the RS485 Fieldbus network ..... 42
  - 4.5 Example of connection to the RS485 supervisor network..... 42
  - 4.6 Power supply connection..... 43
  - 4.7 Wiring..... 43
  - 4.8 Functional notes and differences between DP and AS sensors (with analogue output) ..... 44
  - 4.9 Table of main variables-parameters for serial sensors..... 45
  - 4.10 General warnings..... 46
  - 4.11 Examples of applications..... 47
  - 4.12 Chemical compatibility table for humidity sensor..... 49
  - 4.13 Assembly and fastening the instrument..... 50
  - 4.14 Changing the default configuration for the wall sensor and duct sensor ..... 51
  - 4.15 Version with NTC output only ..... 52
  - 4.16 Resistance values of the CAREL NTC temperature sensors ..... 53
- 5. Technical specifications ..... 54
  - 5.1 Cleaning and maintenance..... 56
  - 5.2 Disposal of the instrument..... 56
- 6. Warnings for the replacement of the AS\* series..... 56
- 7. Mechanical dimensions..... 57
  - 7.1 Model DPW ..... 57
  - 7.2 Model DPD ..... 57
  - 7.3 Model DPP..... 57





1. INTRODUCTION

The DP\* series temperature and humidity sensors represent the latest version of the CAREL sensors for rooms, industrial environments and ducts, developed for the residential and light industrial HVAC/R market, with the quality that CAREL stand out for.

The range includes models with 0 to 10 V output and with RS485 serial output (Carel or Modbus).

The DP\* series sensors use sensors with a digital output, and feature a wider temperature and humidity range than the previous models, ensuring all the versatility required by the applications in the specific market, with excellent and quality / price ratio.

These sensors are typically used together with the Carel controllers, however they can also be used with third party devices.

1.1 General features

The CAREL electronic temperature and/or humidity sensors have been developed for applications in the heating, refrigeration and air-conditioning sectors.

The following models are available: a) wall, b) industrial environment, c) duct. The various models differ due to the different active outputs (current or voltage, selectable by jumpers) except for the models with NTC resistive temperature output (hereinafter indicated as "NTC res."), compatible with CAREL controllers. A model is also available with optically-isolated RS485 serial output for connection to the serial line (pCO or Carel supervisor).

The sensors can have an alternating current (12 to 24 Vac) or direct current (9 to 30 Vdc) power supply.

Wall sensors (DPW\*)

These are used in heating and air-conditioning systems. Their design makes them suitable for use in the home. Ready for wall-mounting.

Sensors for industrial environments (DPP\*)

These are used in industrial environments (cold rooms, pools etc.) where a high index of protection is required, both for the case (IP55) and the sensors (IP54). Ready for wall-mounting.

Duct sensors (DPD\*)

These are used in ducted heating and air-conditioning systems. Supplied together with a fastening bracket.

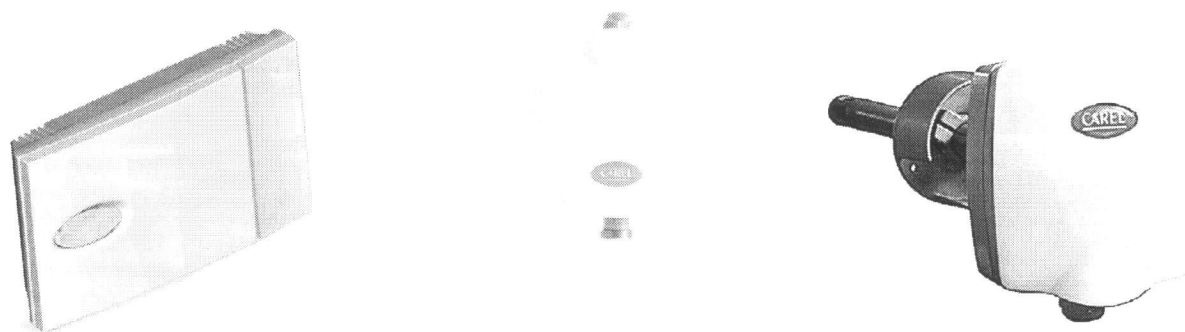

Fig. 1.a

Wall  
DPW\* series

Industrial environment  
DPP\* series

Duct  
DPD\* series

2. CAREL CODING

1 and 2 Series	3 Type	4 Measurement	5 Humid. sensor	6 Temp. sensor	7 Type of output	8 and 9 Custom	10 Packaging
----------------	--------	---------------	-----------------	----------------	------------------	----------------	--------------

1 and 2 Series: DP (Digital sensors)

3- Type: W = Wall  
P = Industrial environment  
D = Duct

4- Measurement: T = Temperature  
H = Humidity  
C = Temperature and Humidity.

5- Type of humidity sensor: 0 = Not present;  
1 = 10 to 90% rH;  
2 = 0 to 100% rH.

6- Type of temperature sensor: 0 = Not present;  
1 = NTC.

7- Type of output: 0 = 0 to 1 Vdc or 4 to 20 mA output;  
1 = 0 to 1 V or 4 to 20 mA and NTC resistive output;  
2 = 0 to 10 Vdc output;  
3 = Modbus/Carel RS485 serial output, not optically-isolated;  
4 = Modbus/Carel optically-isolated RS485 serial output;  
5 = 0 to 10 V and NTC resistive output.

8 and 9 Custom features:

10- Packaging: 0 = Single;  
1 = Multiple;  
N = Neutral;  
\* = Customised.

### 3. CODES AND COMPATIBILITY WITH THE AS\* SERIES

The table below describes the codes available and compatibility with the AS\* series.

#### ACTIVE WALL SENSORS "DPW"

DP series	Description of DP range: active wall sensors (power supply: 9 to 30 Vdc/ 12 to 24 Vac, selectable output: 0...1V/-0.5 to 1 Vdc/4 to 20 mA)	AS series
DPWT010000	Temperature (-10T60 °C)	ASWT030000
DPWT011000	Temperature (-10T60 °C) (resistive CAREL NTC output only)	ASWT011000
DPWC111000	Temperature (-10T60 °C) (resistive CAREL NTC output) and humidity (10 to 90% rH)	ASWC111000 ASWH100000 humidity model only
DPWC110000	Temperature (-10T60 °C) and humidity (10 to 90% rH)	ASWC110000

DP series	Description of DP range: Active wall sensors (power supply: 9 to 30 Vdc/ 12 to 24 Vac, 0 to 10 Vdc output)	AS series
DPWC115000	Temperature (-10T60 °C) (resistive CAREL NTC output) and humidity (10 to 90% rH)	ASWC115000
DPWC112000	Temperature (-10T60 °C) and humidity (10 to 90% rH)	ASWC112000

DP series	Description of DP range: Active wall sensors (power supply: 9 to 30 Vdc/ 12 to 24 Vac, optically-isolated RS485 serial output)	AS series
DPWC114000	Temperature (-10T60 °C) and humidity (10 to 90% rH)	-
DPWT014000	Temperature (-10T60 °C)	-

DP series	Description of DP range: Active wall sensors (power supply: 9 to 30 Vdc/ 12 to 24 Vac, RS485 serial output, NOT optically-isolated)	AS series
DPWC113000	Temperature (-10T60 °C) and humidity (10 to 90% rH)	-
DPWT013000	Temperature (-10T60 °C)	-

#### ACTIVE SENSORS FOR INDUSTRIAL ENVIRONMENTS "DPP"

DP series	Description of DP range: Active sensors for industrial environments (power supply: 9 to 30 Vdc/ 12 to 24 Vac, selectable output: 0...1V/-0.5 to 1 Vdc/4 to 20 mA)	AS series
DPPT010000	Temperature (-20T70 °C)	-
DPPT011000	Temperature (-20T70 °C) (resistive CAREL NTC output only)	ASPT011000
DPPC111000	Temperature (-10T60 °C) (resistive CAREL NTC output) and humidity (10 to 90% rH)	-
DPPC110000	Temperature (-10T60 °C) and humidity (10 to 90% rH)	ASPC110000
DPPC210000	Temperature (-20T70 °C) and humidity (0 to 100% rH)	ASPC230000/ ASPC230010

DP series	Description of DP range: Active sensors for industrial environments (power supply: 9 to 30 Vdc/ 12 to 24 Vac, 0 to 10 Vdc output)	AS series
DPPC112000	Temperature (-10T60 °C) and humidity (10 to 90% rH)	-
DPPC212000	Temperature (-20T70 °C) and humidity (0 to 100% rH)	-

DP series	Description of DP range: Active sensors for industrial environments (power supply: 9 to 30 Vdc/ 12 to 24 Vac, optically-isolated RS485 serial output)	AS series
DPPT014000	Temperature (-20T70 °C)	-
DPPC114000	Temperature (-10T60 °C) and humidity (10 to 90% rH)	-
DPPC214000	Temperature (-20T70 °C) and humidity (0 to 100% rH)	-

DP series	Description of DP range: Active sensors for industrial environments (power supply: 9 to 30 Vdc/ 12 to 24 Vac, RS485 serial output, NOT optically-isolated)	AS series
DPPT013000	Temperature (-20T70 °C)	-
DPPC113000	Temperature (-10T60 °C) and humidity (10 to 90% rH)	-

**ACTIVE DUCT SENSORS "DPD"**

DP series	Description of DP range: Active duct sensors (power supply: 9 to 30 Vdc/ 12 to 24 Vac, selectable output: -0.5 to 1 Vdc/4 to 20 mA)	AS series
DPDT010000	Temperature (-20T70 °C)	ASDT030000
DPDT011000	Temperature (-20T70 °C) (resistive CAREL NTC output only)	ASDT011000
DPDC111000	Temperature (-10T60 °C) (resistive CAREL NTC output) and humidity (10 to 90% rH)	ASDC111000
DPDC110000	Temperature (-10T60 °C) and humidity (10 to 90% rH)	ASDC110000 ASDH100000** (*humidity only)
DPDC210000	Temperature (-20T70 °C) and humidity (0 to 100% rH)	ASDC230000 ASDH20000** (*humidity only)

DP series	Description of DP range: Active duct sensors (power supply: 9 to 30 Vdc/ 12 to 24 Vac, 0 to 10 Vdc output)	AS series
DPDC112000	Temperature (-10T60 °C) and humidity (10 to 90% rH)	-
DPDC212000	Temperature (-20T70 °C) and humidity (0 to 100% rH)	-

DP series	Description of DP range: Active duct sensors (power supply: 9 to 30 Vdc/ 12 to 24 Vac, optically-isolated RS485 serial output)	AS series
DPDT014000	Temperature (-20T70 °C)	-
DPDC114000	Temperature (-10T60 °C) and humidity (10 to 90% rH)	-
DPDC214000	Temperature (-20T70 °C) and humidity (0 to 100% rH)	-

DP series	Description of DP range: Active duct sensors (power supply: 9 to 30 Vdc/ 12 to 24 Vac, RS485 serial output, NOT optically-isolated)	AS series
DPDT013000	Temperature (-20T70 °C)	-
DPDC113000	Temperature (-10T60 °C) and humidity (10 to 90% rH)	-

Neutral or customised versions available upon specific request.

4. INSTALLATION

4.1 Connections for sensors with analogue output

Below are the wiring diagrams showing the connections to the terminal block and the position of the jumpers for configuring the universal voltage (default) or current output.

**DPWxxx0xxx Out both**  
 DPDxxx0xxx 0...1 V o 4-20 mA -0.5-1 Vdc  
 DPPxxx0xxx

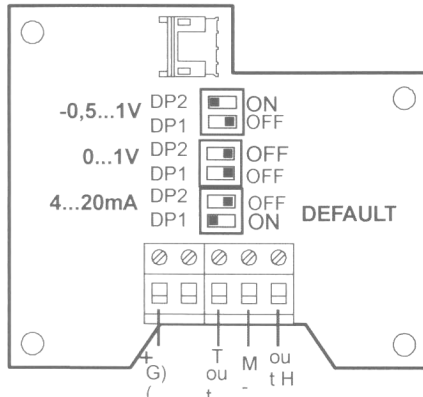

**DPWxxx1xxx Out NTC Res. for temperature**  
 DPDxxx1xxx 0...1 V o 4-20 mA -0.5-1 Vdc humidity  
 DPPxxx1xxx

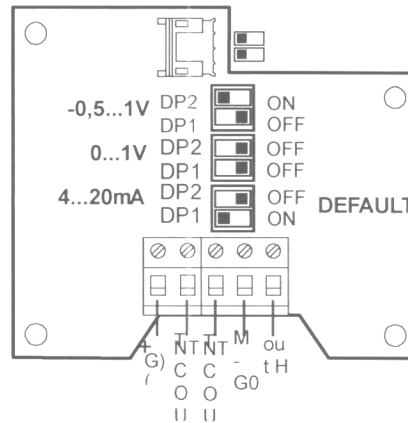

DP1 ON -0.5 to 1 V | R min. 1 kohm  
 DP2 OFF  
 DP1 ON 0 to 1 V  
 DP2 OFF  
 DP1 ON 4 to 20 mA | R max 100 kohm  
 DP2 OFF

Jumpers for configuring the outputs on models with two active outputs both are configured in the same way.

**DPWxxx2xxx Out both**  
 DPDxxx2xxx 0-10V  
 DPPxxx2xxx

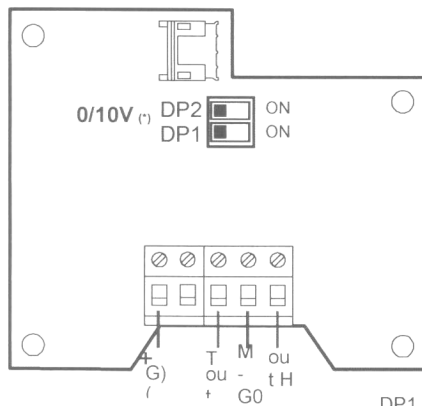

DP1 ON 0 to 10 V | R min. 1 kohm  
 DP2 ON

**DPWxxx5xxx Out NTC Res. temperature**  
 DPDxxx5xxx 0-10 V humidity  
 DPPxxx5xxx

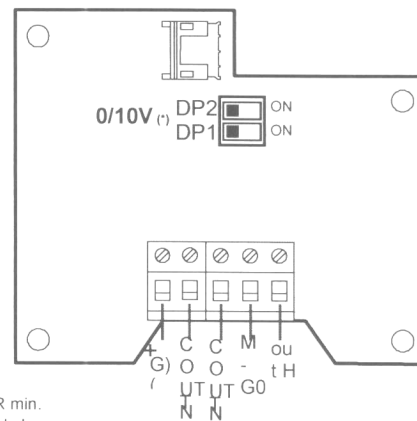

(\*) 0-10 V version= default configuration

Fig. 4.a

- Key:
- out T = temperature output -0.5 to 1 Vdc or 0 to 1 Vdc or 4 to 20 mA for models (DPxxx0 or 1);
  - out T = temperature output 0 to 10 Vdc for models (DPxxx2 or 5);
  - out H = humidity output -0.5 to 1 Vdc or 0 to 1 Vdc or 4 to 20 mA for models (DPxxx0 or 1);
  - out H = humidity output 0 to 10 Vdc for models (DPxxx2 or 5);
  - out NTC = output with NTC resistive sensor 10K at 25°C (Carel standard);
  - M(G0) = reference for both power supply and outputs;
  - + (G) = power supply (12 to 24 Vac or 9 to 30 Vdc).

- Note:
- with output configured for 0 to 1 Vdc or 0-10Vdc the load must be >1K Ω;
  - with output configured for 4 to 20 mA the load must be < 120 Ω;
  - with NTC resistive output the two signals are isolated from the reference M(G0).

Wiring the sensor to the instrument

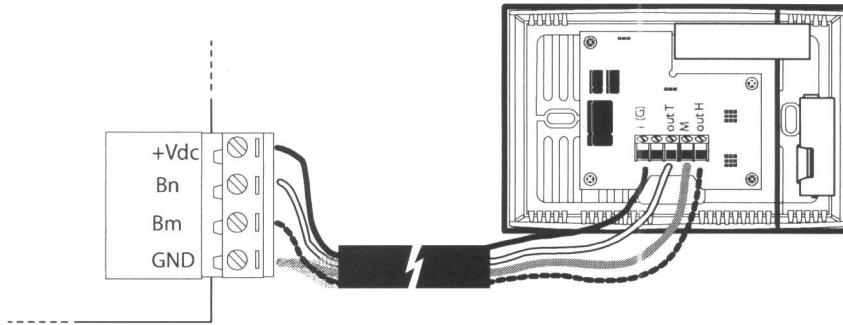

Fig. 4.b

Wiring the sensor to the instrument when an additional external transformer is required

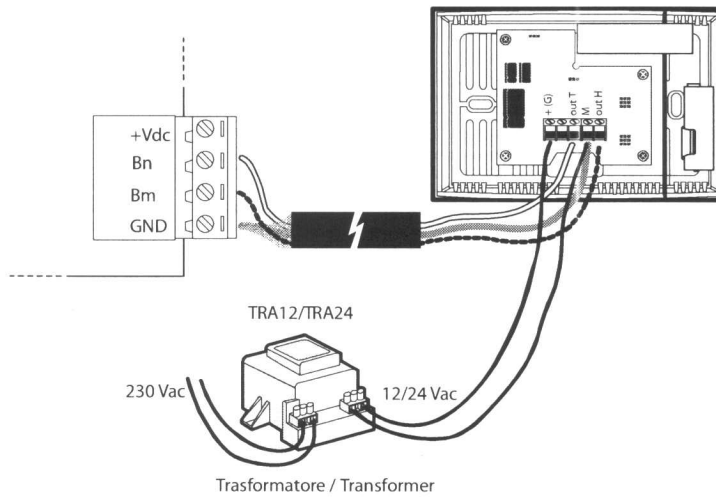

Fig. 4.c

Wiring the sensor with voltage or current output

Sensor connection with voltage or current output and power supply directly from the controller. The power supply capacity (maximum current) of the controller must be evaluated. For distances > 10 metres, the 4-20 mA current connection should be used, to avoid measurement errors due to the drop in the reference M (G0). Sensor connection with separate power supply via transformer, used to avoid measurement errors due to current on reference M(G0) connection or for power supply problems on G0 with earth connection.

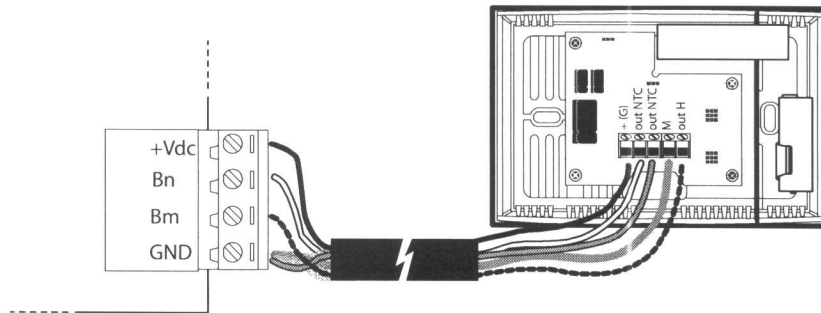
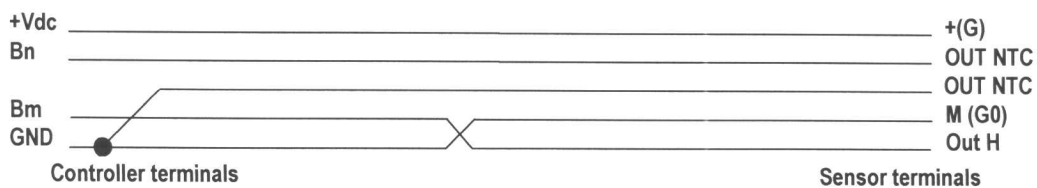

Fig. 4.d

Wiring the sensor to the instrument with NTC resistive output

Sensor connection with NTC resistive output: the two signals must be connected directly to the terminals on the instrument, Do not use M(G0) as the common for the connection.

Connection wiring diagram



### 4.2 Connections for sensors with RS485 serial output

Below are the wiring diagrams showing the connections to the terminal block, and the settings of the dipswitches for configuring the RS485 serial communication mode with Carel or ModBus protocol.

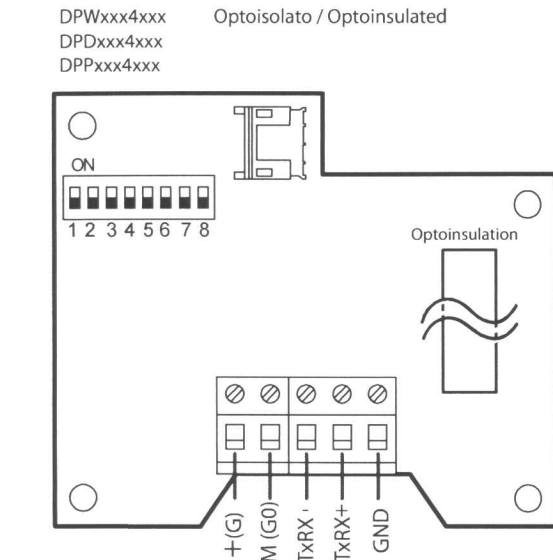

Dipswitch settings valid for all models

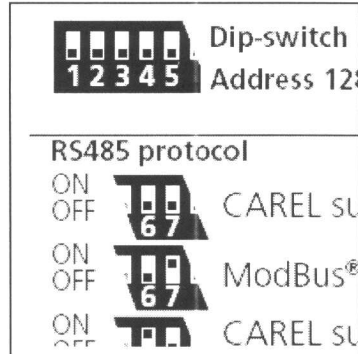
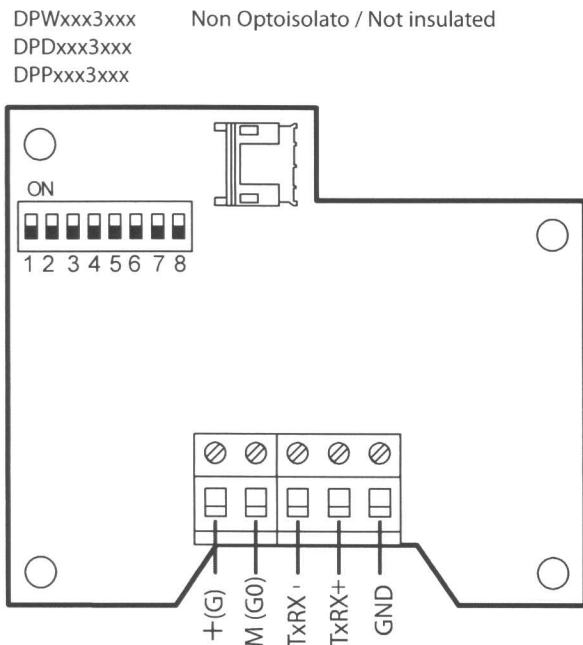

Fig. 4.e



Key:

TxRx+ = RS485 serial output positive  
 TxRx- = RS485 serial output negative  
 GND = reference for RS485 serial connection

M(G0) = power supply reference  
 +(G) = power supply (12 to 24 Vac or 9 to 30 Vdc);

Note: for the models that are NOT isolated, GND is connected to M(G0)  
 for the optically-isolated models, GND is isolated from M(G0)

The following figure shows the connection between the sensors with serial output and the pCO1 controller, which must be fitted with the PCO100FD10 option.

For the connection to supervisory systems, all the RS485 interfaces featured can be used.

Fig. 4.f

### 4.3 Example of configuring the RS485 serial sensor

The 8 dipswitches (DP1, 8) can be configured to set the address, the serial transmission mode and speed.

- Select address (DIP 1-5). The selection follows the rules of 5-bit binary coding.  
 Example: Off-Off-Off-Off-Off 128 / On-Off-On-Off-Off 128+5=133;
- CAREL / Modbus® supervisor protocol (or Auto);  
 Serial speed (9600/19200 bit/sec);



4.4 Example of connection to the RS485 Fieldbus network

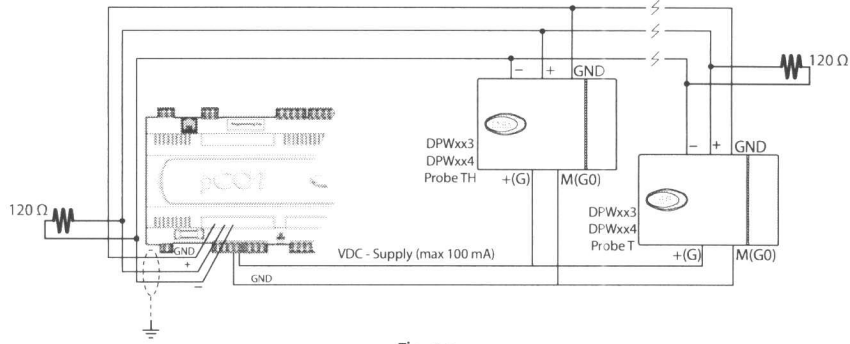

Fig. 4.g

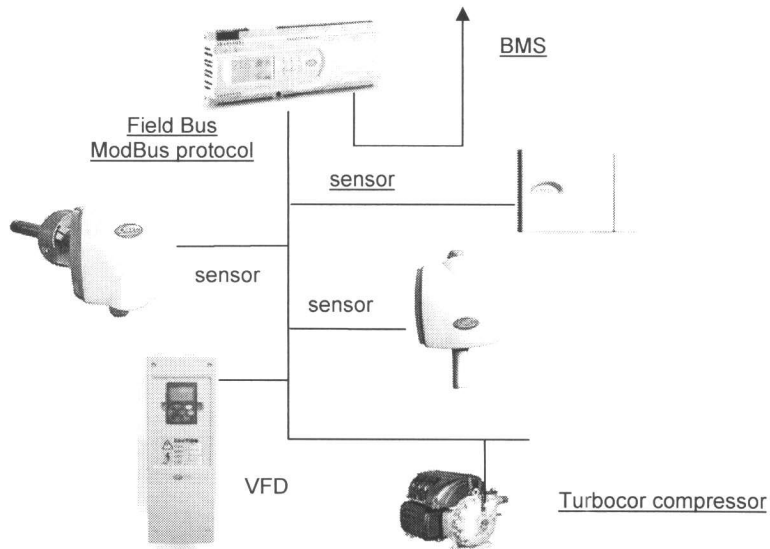

Fig. 4.h

4.5 Example of connection to the RS485 supervisor network

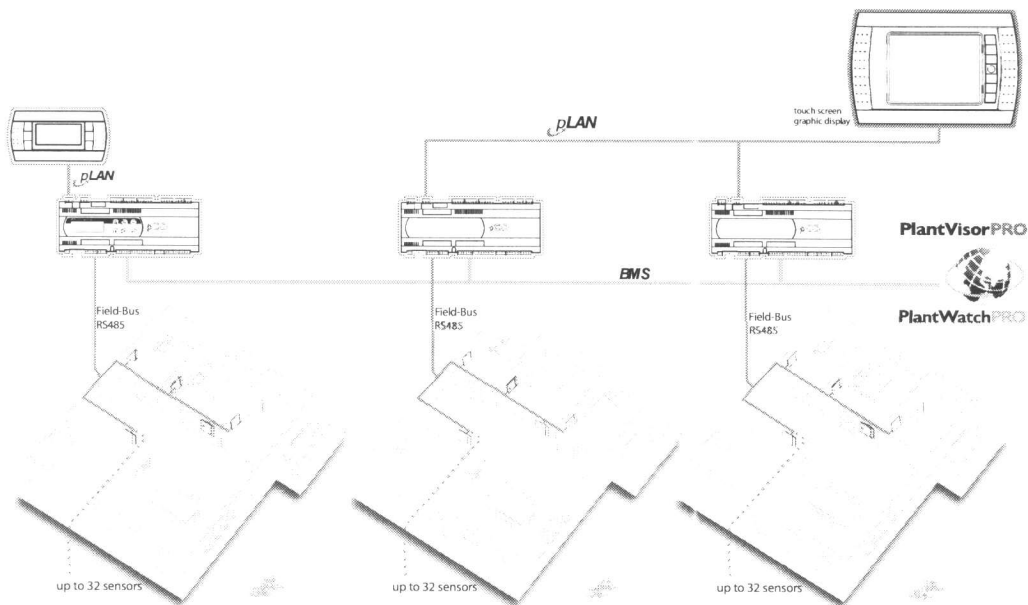

Fig. 4.i

#### 4.6 Power supply connection

For alternating current power supply (12 to 24 Vac), just one transformer can be used, connected to G-G0 on all the sensors with G0 to earth, paying special care to observe the polarity by connecting together the terminals with the same name, or alternatively using an isolating transformer for each individual sensor.

For the serial sensors, the type of power supply depends on the model of sensor used:

sensors with optical isolation can be powered with one power supply, G-G0, for all the sensors as well as for the controller. In this case, make sure that the cable shield on the controller side is connected to EARTH, directly or via the G0-Earth connection on the controller.

Sensors that are NOT isolated: for short distances, these can be powered with one power supply, for distances over 10 m, an isolating transformer may be required for each sensor.

#### 4.7 Wiring

For wiring a shielded multicore cable with 3 to 5 wires, depending on the model.

The maximum cross-section of the wires allowable for the terminals is 1.5 mm<sup>2</sup>. In versions DPP\* and DPD\*, the maximum inside diameter of the cable gland is 8 mm.

##### Serial version with RS485 output

For sensors with serial connection, the cable use must have the following characteristics:

- twisted pair;
- shielded, preferably with earth wire;
- size AWG20 (diam. 0.7 to 0.8 mm; area 0.39 to 0.5 mm<sup>2</sup>) or AWG22 (diam. 0.55 to 0.65 mm; area 0.24 to 0.33 mm<sup>2</sup>);
- rated capacitance between the wires <100 pF/m.

##### Analogue version with 0 to 1 Vdc or -0.5 to 1Vdc output signal

On the models with active outputs (not NTC res.) configured for voltage signals, the voltage drop over the cables must be kept in mind: the effect of the drop over 1 mm<sup>2</sup> in cross-section means a variation of 0.015 °C for each metre of cable (0.015 °C m/mm<sup>2</sup>) in the temperature measurement, and a variation of 0.015% rH for each metre of cable (0.015% rH m/mm<sup>2</sup>) in the humidity measurement.

Below is an example that shows the calculation of the variations that cause temperature and humidity errors.

##### Example:

Cable length	Cable cross-section	Temperature error	Humidity error
30 m	0.5 mm <sup>2</sup>	0.9 °C	0.9% rH
30 m	1.5 mm <sup>2</sup>	0.3 °C	0.3% rH

To avoid measurement errors due to the supply current, an additional power supply from an external transformer can be used (CAREL transformer codes TRA12VDE00 or TRA2400001), to be connected as shown in the figure (2' with transf.). With this configuration the maximum distance is 100 m (note<sup>1</sup>)

The transformer must not be earthed and can be installed in the panel together with the controller. The connection cable must be multicore with 4 or 5 wires. In this situation, no supply current runs through connection M(G0). In installations with multiple sensors, use a transformer for each sensor to avoid measurement errors.

##### Analogue version with 4 to 20 mA output signal

For distances over 30 m, the current output should be selected, if the system allows. The maximum installation distance for the current output is 200 m (note<sup>1</sup>).

In the case of AC power supply, the wires used must have a cross-section of 1.5 mm<sup>2</sup> to reduce noise due to the supply current. Such noise may, in some cases, cause instability in the measurement, which can be eliminated using a DC power supply or with an additional power supply, as shown in the figure (2' with transf.).

4.8 Functional notes and differences between DP and AS sensors (with analogue output)

On power-up, the DP sensors (excluding the serial and NTC temperature sensors) provide an output value (voltage or current) that is out-of-range (with a negative value), and that stabilises at the final reading in a maximum of 20 to 30 s. If the controllers feature alarm signals for readings that are out-of-range, such signals may be activated, however they are cancelled in the time indicated.

For the digital measurement of the signal between the main board and the sensor board, a temperature and humidity measurement refresh period of 15s is used, which may introduce a delay in the reading.

If the outputs (voltage and current) are overloaded, the output is reset for a minimum measurement cycle (15 s).

Communication errors with the sensor board also reset the outputs.

The condition with 0 V output can be used to manage sensor errors on the controllers, and is available for 0 to 1 V, 0 to 10 V and 4 to 20 mA outputs, yet not for -0.5 to 1V.

**WARNING!**

The sensors are configured by default with 4 to 20 mA output. Before connecting to the controller, check the compatibility of the input. To set a different configuration on the sensor, change the default configuration.

On sensors with temperature and humidity output, both channels are configured in the same way, and mixed connections of the outputs are not possible. For 0 to 1 V, 0 to 10 V and 4 to 20 mA outputs, the start and end scale values are different from the AS\* series analogue sensors (see the table below).

Sensors with normalised output: 0 to 1 V / 0 to 10 V / 4 to 20 mA	
-30 to 70°C	0 to 100% rH
0 to 1 V	0 to 1 V
0 to 10 V	0 to 10 V
4 to 20 mA	4 to 20 mA
Sensors with output: -0.5 to 1V	
-30 to 70°C	0 to 100% rH
-0.3 to 0.7V	0.0 to 1 V

Start and end range limits to be set on the controllers. These are independent of the effective range of measurement.

Example. For code DPWC110000 (-10 to 60°C and 10 to 90% rH)

For 0 to 1 V, 0 to 10V, 4 to 20 mA outputs set:

0 to 1 V	0V at -30°C and 0% rH	...	1V at 70°C and 100% rH
0 to 10 V	0V at -30°C and 0% rH.	...	10V at 70°C and 100% rH
4 to 20 mA	4mA at -30°C and 0% rH	...	20mA at 70°C and 100% rH

For -0.5 to 1V output (the limits generally do not need to be set)

-0.3V at -30°C	....	+0.7V at 70°C
0V at 0% rH	...	1V at 100% rH

## 4.9 Table of main variables-parameters for serial sensors

The main feature of serial sensors is that they communicate data via the RS485 serial line (which can be configured by dipswitch). The parameters can be accessed via serial line using the Carel supervisor or Modbus protocols.

The unit code of the board is 59 (MAC parameter)

Below is the table of the parameters and status variables:

Name	Description	Read Write	Type A/I/D	UOM	#N/D	Min	Max	Def	SPV index	ModBus index
OFT	Temperature offset	R/W	A	°C x 10	EEPROM	-100	100	0	1	1
OFH	Humidity offset	R/W	A	% x 10	EEPROM	-100	100	0	2	2
DLT	Differential for updating the temperature	R/W	A	°C x 10	EEPROM	0	20	5	3	3
DLH	Differential for updating the humidity	R/W	A	% x 10	EEPROM	0	20	5	4	4
RSV	Reserved – Not used	R	A	-	-	0	0	-	(5)	5
TMP	Temperature value read by the sensor	R	A	°C x 10	RAM	-500	1000	-	6	6
UMI	Humidity value read by the sensor	R	A	% x 10	RAM	0	1000	-	7	7
RUG	Dewpoint value	R	A	°C x 10	RAM	-500	2000	-	8	8
DIP	Describes the status of the dipswitch	R	I	-	RAM	0	255	-	6	134
ERR	Describes the status of the errors for the TH sensor and the dewpoint	R	I	-	RAM	0	4095	-	7	135
EEP	Reset default values. 1 = default (returns to 0 automatically).	R/W	D	-	RAM	0	1	-	6	6
ERT	Temperature sensor reading error	R	D	-	RAM	0	1	-	7	7
ERH	Humidity sensor reading error	R	D	-	RAM	0	1	-	8	8
ETR	Dewpoint calculation error	R	D	-	RAM	0	1	-	9	9

### Notes:

A indicates analogue variables, the value transferred is in tenths (x10);

D indicates digital variables;

I indicates integer variables;

### Output variables

**TMP:** analogue value of the temperature read by the sensor;

**UMI:** analogue value of the relative humidity read by the sensor;

**RUG:** dewpoint temperature value (@ std. atm. press.) calculated based on the two temperature and humidity measurements. Range from -20 to +70 °C with humidity from 5 to 95% rH.

**DIP:** describes the status of the dipswitch.

### Configuration parameters (saved in Flash / EEPROM)

**OFT:** used to calibrate the external HW connected to the sensor and specifies the offset to add to or subtract from the value read before being sent to the supervisor

**OFH:** used to calibrate the external HW connected to the sensor and specifies the offset to add to or subtract from the value read before being sent to the supervisor

- **DLT:** The value of the TMP variable is not updated if the temperature does not exceed this differential
- **DLH:** The value of the UMI variable is not updated if the humidity does not exceed this differential, used to limit the number of variations with data transfer on the serial line.

### Errors: Output variables

**EEP:** digital value for the write error to Flash. Can be written and used to load the default values.

**ERT:** indicates that the data relating to the TMP parameter is not correct. This alarm can be generated if the sensor measures a value that is out-of-range or if there is a communication problem.

**ERH:** indicates that the data relating to the UMI parameter is not correct. This alarm can be generated if the sensor measures a value that is out-of-range or if there is a communication problem.

**ETR:** indicates that the data relating to the RUG parameter is not correct, generated if ERT and/or ERH are equal to 1.

**ERR:** Describes the status of all the alarms, as follows:

**Bit0:** The humidity sensor is out-of-range

**Bit1:** The UMI parameter is not updated due to I2C communication problems

**Bit4:** The temperature sensor is out-of-range

**Bit5:** The TMP parameter is not updated due to I2C communication problems

**Bit8:** The RUG parameter is not correct due to UMI and TMP being out-of-range

**Bit9:** The RUG parameter is not updated due to I2C communication problems

#### 4.10 General warnings

---

- To maintain the index of protection declared in the versions with "IP55" case, the wiring must use multicore cables, with the outer sheath having a maximum diameter of 8 mm.
- It is recommended to use shielded cables. The cables carrying the temperature and humidity signals must not run near the 115 to 230 or 400 to 480 Vac power cables, or near cables that power from the contactors to the loads. Measurement errors due to electromagnetic coupling must be avoided.
- The sensor power supply and electrical signals are very low voltage, nonetheless for connection to the controllers, remember that supplementary electrical insulation is required, excluding the "sensor protection" cap. The metal protection of the sensors is connected to the sensor power supply reference. For conformity to the safety standards, double insulation must be used for the power supply to the sensor and the controller it is connected to, if the sensor zone is accessible to the user in the installation.  
The sensors can be integrated into Class 1 or 2 equipment, with the following warnings:

**Class 1:**

- the power supply reference G0 must be earthed.

**Class 2:**

- double insulation or reinforced insulation must be used for the power supply to the sensor and the controller it is connected to. If this is not possible, in normal use, the sensor zone must be made inaccessible to the users.
- Do not expose to sources of heat or direct sunlight.

**Note:**

For the connection of the analogue outputs at distances over 30 m, the installer must make sure that the suitable precautions and protectors specified have been applied in compliance with the standards, so as to avoid faults due to surge. Depending on the installation, the shield of the analogue signal connection cables may need to be earthed.

## 4.11 Examples of applications

### Applications

All the sensors can be connected to CAREL controllers for measuring the temperature and humidity values; below are examples of some connections to CAREL controllers.

### Examples of connections

#### pCO<sup>3</sup>

pCO	Sensor
Bn= 1, ..., 4	ntc = sensor NTC output (res.)
Bn= 5, ..., 8	out T = active temperature output
Bm= 5, ..., 8	out H = active humidity output
AVSS	M = reference
+24 Vdc	+ (G) = power supply

The shield must be connected to AVSS

#### pCO<sup>2</sup>

pCO	Sensor
Bn= 1, ..., 10	ntc = sensor NTC output (res.)
Bn= 1, ..., 3 = 6, ..., 8	out T = active temperature output
Bn= 1, ..., 3 = 6, ..., 8	out H = active humidity output
GND	M = reference
+Vdc	+ (G) = power supply

The shield must be connected to GND

#### pCO<sup>1</sup>

pCO	Sensor
Bn= 1, ..., 8	ntc = sensor NTC output (res.)
Bn= 1, ..., 4	out T = active temperature output
Bn= 1, ..., 4	out H = active humidity output
GND	M = reference
+Vdc	+ (G) = power supply

The shield must be connected to GND

### IR universal

IR32	Sensor
7	ntc = sensor NTC output (res.)
8	ntc = sensor NTC output (res.)
IR32	Sensor
9	out T = active temperature or humidity output
7	M = reference
8	+ (G) = power supply

The shield must be connected to 7

### IRDR

IRDR	Sensor
2	ntc = sensor NTC output (res.)
3	ntc = sensor NTC output (res.)

The shield must be connected to "2"

IRDR	Sensor
3	out T = active temperature or humidity output
1	M = reference
2	+ (G) = power supply

The shield must be connected to "1"

Example of connection with two IR instruments that must be powered separately from the power supply line by two different transformers.

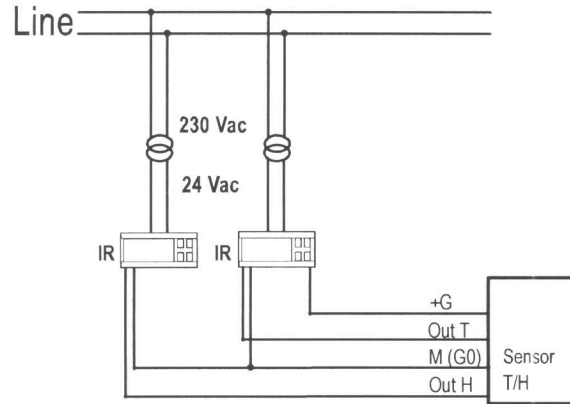

Fig. 4.1

FCM

FCM	1st sensor
7	out T/H (4 to 20 mA) = active temperature or humidity output
8	M = reference
6	+ (G) = power supply

The shield must be connected to "8"

FCM	1st sensor
10	out T/H (4 to 20 mA) = active temperature or humidity output
11	M = reference
9	+ (G) = power supply

FCM	2nd Sensor
10	out T/H (4 to 20 mA) = active temperature or humidity output
11	M = reference
9	+ (G) = power supply

The shield must be connected to "11"

Note: with one sensor the R200 Ω resistor does not need to be connected, if terminals 7-B1 and 10-B2 are jumpered.

"SD" humidifiers

SD	Sensor
57	out H = active humidity output
58/59	M = reference
56	+ (G) = power supply

The shield must be connected to 58/59

"heaterSteam", "humiFog" and "humiSteam" humidifiers

Humicontrol	Sensor
5l	out H = active humidity output
6l	M = reference
4l	+ (G) = power supply

The shield must be connected to 6l.

"MC" humidifiers

MC	Sensor
4	out H = active humidity output
3	M = reference
5	+ (G) = power supply

The shield must be connected to 2 (for both the sensors)

HumiSonic humidifiers

CDA 303	Sensor
S1	out H = active humidity output
GND/S2	M = reference
+VR	+ (G) = power supply

The shield must be connected to GND/S2

N.B. make sure that the inputs on the controllers and the corresponding active outputs of the sensor connected have the same current or voltage configuration; the parameters must be set accordingly.

4.12 Chemical compatibility table for humidity sensor

Legend for the table below: a --> 1 hour immersion 100% solution;  
 b --> 30 min. immersion;  
 c --> Deviations in presence of chemicals (@ ppm).

All tests are made in standard environments after exposure to liquids o gas.  
 Only if indicated with ( c ) tests are in presence of chemicals

Chemicals	Immersion in liquids			In GAS (@ x ppm)		
	No effect, deviation less than 1% rh	Reversible effect, deviation less than 5% rh	Large effect, not reversible, failed sensor	No effect, deviation less than 1% rh	Reversible effect, deviation less than 5% rh	Large effect , not reversible , failed sensor
<b>Test after exposure to Chemicals</b>						
De-Icing		X (a)				
Pyrethum Extract		X (a)				
Tricloroethane		X (a)				
1,2 Propandiole		X (a)				
Cycloexane		X (a)				
Di-Isopropile-Ether	X (b)					
Isoproanole	X (b)					
Ethile-Glycole	X (b)					
Ethanole	X (b)					
Toluole	X (b)					
Temperature Shock -20/+93C	X (b)					
Hot Water 93C - 18h	X (b)					
Tap Water	X					
Pressure Cocker	X					
Ethyle-Acetate	X (b)					
Motor Oil 10W-40	X (b)					
Butyle-Acetate		X (b)				
CH4 Methane 11 days @ 29000 ppm					X	
NH3 Ammonium 11 Days @ 1000 ppm					X	
Harshest Enviromental Test : - Motor Oil @ 160 C - Liquid Nitrogen @ -195C - Toluole immersion for cleaning	X @ 100 times	X @ 250 times				
hydrochloric acid 32%			X			
hydrofluoric acid 40%			X			
sulfuric acid 90%			X			

<b>Test in presence of chemicals</b>						
NH3 Ammonium	50 ppm				X (c)	
NH3 Ammonium	100 ppm				X (c)	
CO2 Carbon dioxide	5000 ppm				X (c)	
NO2 Nitrogen bioxide	3 ppm				X (c)	
H2S Hydrogen sulphur	1 ppm				X (c)	
H2 Hydrogen	3500 ppm				X (c)	
Cl Chlorine	1 ppm				X (c)	

Warning! Not suitable for use in explosive environments.



4.13 Assembly and fastening the instrument

Wall version

The wall version is wall or panel mounted.

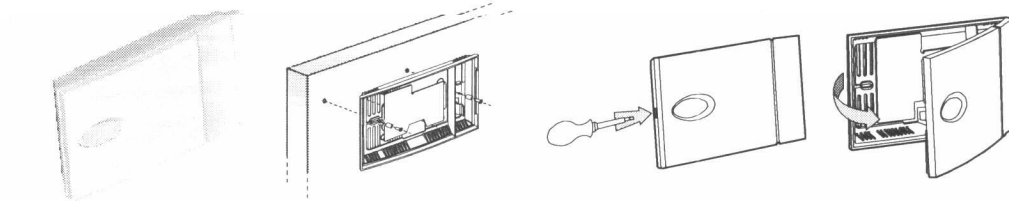

Fig. 4.m

Assembly notes

- Open the case using a flathead screwdriver in the slot, paying extra care not to damage the electronic parts;
- Move the cap with the temperature and humidity sensors on the rear of the sensor;
- Fasten the rear of the sensor case to the panel or the wall (use the screws supplied together with the sensor);
- Reposition the temperature and humidity sensors in the socket;
- Close the sensor with the top cover by pressing lightly.

Industrial environment version

The industrial environment version is wall or panel mounted.

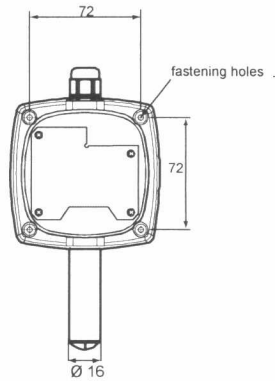

Fig. 4.n

Assembly notes

- Open the case by turning the top cover anticlockwise;



Fig. 4.n1

- Fasten the rear of the sensor case to the panel or the wall (use the screws supplied together with the sensor) placing the screws in the holes provided.

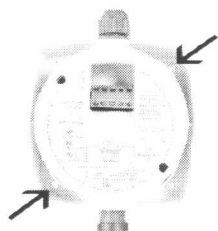

Fig. 4.n2

- Make sure that the screws that hold the board protective cover are fastened tightly.

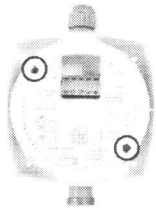

Fig. 4.n3

- Close the sensor by turning the cover clockwise;

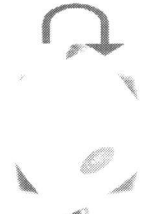

Fig. 4.n4

For the electrical connections, remove the top cover of the sensor. For the configuration, see the instructions shown below.

**Duct version**

The duct version is connected to the air duct using the special fastening bracket.

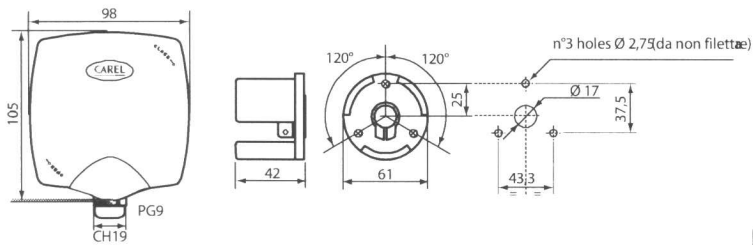

Fig. 4.o

**Assembly notes**

- Fasten the bracket to the air duct;
- Insert the rod on the bracket to the required depth;
- Tighten the screw on the bracket to fasten

For the electrical connections, remove the top cover of the sensor. For the configuration, see the instructions shown below.

**4.14 Changing the default configuration for the wall sensor and duct sensor**

To change the default configuration:

6. Remove the cover by rotating it anticlockwise;
7. Remove the two screws and remove the protective cover;
8. Change the selection pin, according to the required configuration;
9. Place the protective cover and fully tighten the two screws;
10. Close the cover again by rotating it clockwise.

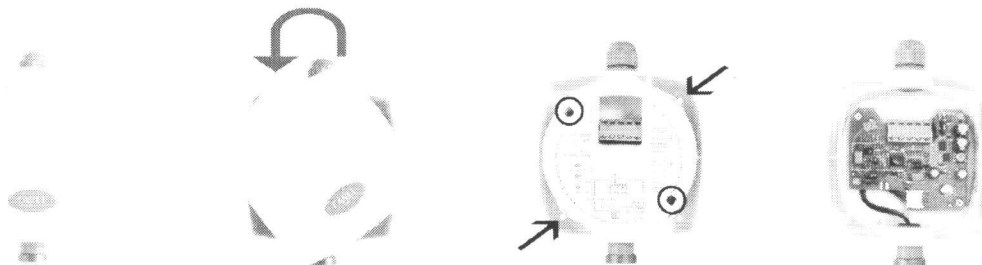

Fig. 4.P

4.15 Version with NTC output only

uses an NTC sensor 10K@25°C (beta 3435), see the table of temperature-resistance shown

- 2.5 mm<sup>2</sup>
- 2.8 mm
- Polyamide PA6
- Chrome-plated brass
- Chrome-plated steel

The temperature-only version with NTC resistive output is shown below, with the following characteristics of the terminal:

- Rated cross-section
- Maximum screwdriver size
- Terminal plastic material
- Terminal
- Terminal screw

Connection example:  
DPW series wall sensors

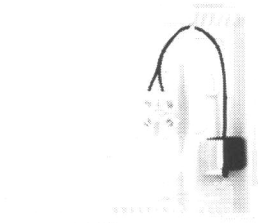

Inside view, bottom shell

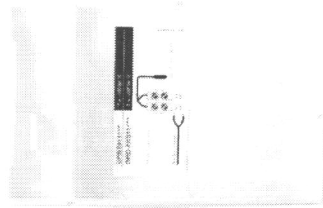

Inside view, top shell



DPD series duct sensors

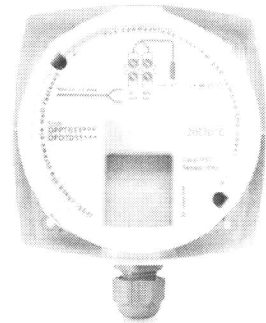

View of sensor without cover

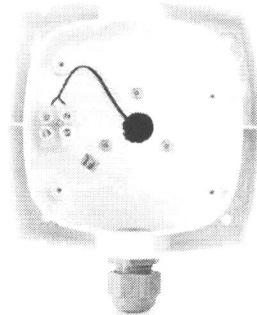

Inside view

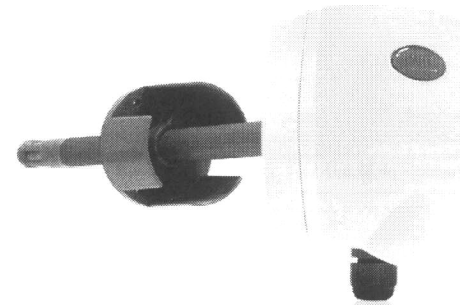

DPP series sensors for industrial environments

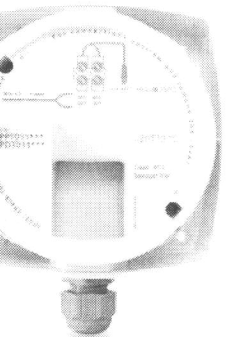

View of sensor without cover

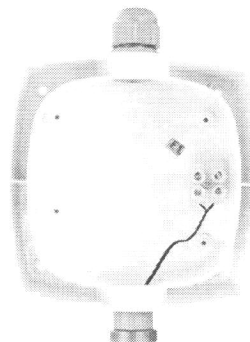

Inside view



View

4.16 Resistance values of the CAREL NTC temperature sensors

Temp.	Resistance value			Temp.	Resistance value			Temp.	Resistance value		
	Max.	Std	Min.		Max.	Std	Min.		Max.	Std	Min.
°C	KΩ	KΩ	KΩ	°C	KΩ	KΩ	KΩ	°C	KΩ	KΩ	KΩ
-50	344.40	329.20	314.70	1	26.64	26.13	25.52	56	3.49	3.42	3.35
-49	324.70	310.70	297.20	2	25.51	25.03	24.55	57	3.39	3.31	3.24
-48	306.40	293.30	280.70	3	24.24	23.99	23.54	58	3.28	3.21	3.14
-47	289.20	277.00	265.30	4	23.42	22.99	22.57	59	3.18	3.11	3.04
-46	273.20	261.80	250.60	5	22.45	22.05	21.66	60	3.09	3.02	2.95
-45	258.10	247.50	237.20	6	21.52	21.15	20.78	61	2.99	2.92	2.86
-44	244.00	234.10	224.60	7	20.64	20.29	19.95	62	2.90	2.83	2.77
-43	230.80	221.60	212.70	8	19.80	19.40	19.15	63	2.81	2.75	2.69
-42	218.50	209.80	201.50	9	19.00	18.70	18.40	64	2.73	2.66	2.60
-41	206.80	198.70	191.00	10	18.24	17.96	17.67	65	2.65	2.58	2.52
-40	195.90	188.40	181.10	11	17.51	17.24	16.97	66	2.57	2.51	2.45
-39	185.40	178.50	171.59	12	16.80	16.55	16.31	67	2.49	2.43	2.37
-38	175.50	168.90	162.00	13	16.13	15.90	15.87	68	2.42	2.36	2.30
-37	166.20	160.10	154.10	14	15.50	15.28	15.06	69	2.35	2.29	2.24
-36	157.50	151.80	140.20	15	14.89	14.68	14.48	70	2.28	2.22	2.17
-35	149.30	144.00	138.80	16	14.31	14.12	13.93	71	2.21	2.16	2.10
-34	141.60	136.60	131.80	17	13.75	13.57	13.40	72	2.15	2.10	2.04
-33	134.40	129.70	125.20	18	13.22	13.06	12.89	73	2.09	2.04	1.98
-32	127.60	123.20	118.90	19	12.72	12.56	12.41	74	2.03	1.98	1.93
-31	121.20	117.10	113.10	20	12.23	12.09	11.95	75	1.97	1.92	1.87
-30	115.10	111.30	107.50	21	11.77	11.63	11.57	76	1.92	1.87	1.82
-29	109.30	105.70	102.20	22	11.32	11.20	11.07	77	1.86	1.81	1.78
-28	103.80	100.40	97.16	23	10.90	10.78	10.60	78	1.81	1.76	1.71
-27	98.63	95.47	92.41	24	10.49	10.38	10.27	79	1.76	1.71	1.68
-26	93.75	90.80	87.93	<b>25</b>	<b>10.10</b>	<b>10.00</b>	<b>9.90</b>	80	1.71	1.66	1.62
-25	89.15	86.39	83.70	26	9.73	9.63	9.52	81	1.66	1.62	1.57
-24	84.82	82.22	79.71	27	9.38	9.28	9.18	82	1.62	1.57	1.53
-23	80.72	78.29	75.93	28	9.04	8.94	8.84	83	1.57	1.53	1.49
-22	76.85	74.58	72.36	29	8.72	8.62	8.52	84	1.53	1.49	1.44
-21	73.20	71.07	68.99	30	8.41	8.31	8.21	85	1.49	1.45	1.40
-20	69.74	67.74	65.80	31	8.11	8.01	7.91	86	1.45	1.41	1.37
-19	66.42	64.54	62.72	32	7.82	7.72	7.62	87	1.41	1.37	1.33
-18	63.27	61.52	59.81	33	7.55	7.45	7.35	88	1.37	1.33	1.29
-17	60.30	58.66	57.05	34	7.28	7.19	7.09	89	1.34	1.30	1.26
-16	57.49	55.95	54.44	35	7.03	6.94	6.84	90	1.30	1.26	1.22
-15	54.83	53.39	51.97	36	6.79	6.69	6.60	91	1.27	1.23	1.19
-14	52.31	50.96	49.83	37	6.56	6.46	6.37	92	1.23	1.20	1.16
-13	49.93	48.65	47.12	38	6.33	6.24	6.15	93	1.20	1.16	1.13
-12	47.67	46.48	45.31	39	6.12	6.03	5.94	94	1.17	1.13	1.10
-11	45.53	44.41	43.32	40	5.92	5.82	5.73	95	1.14	1.10	1.07
-10	43.50	42.25	41.43	41	5.72	5.63	5.54	96	1.11	1.08	1.04
-9	41.54	40.56	39.59	42	5.53	5.43	5.35	97	1.08	1.05	1.01
-8	39.68	38.76	37.85	43	5.34	5.25	5.17	98	1.05	1.02	0.99
-7	37.91	37.05	36.20	44	5.16	5.08	4.99	99	1.03	0.99	0.96
-6	36.24	35.43	34.02	45	4.99	4.91	4.82	100	1.00	0.97	0.94
-5	34.65	33.89	33.14	46	4.83	4.74	4.66	101	0.98	0.94	0.91
-4	33.14	32.43	31.73	47	4.67	4.59	4.51	102	0.95	0.92	0.89
-3	31.71	31.04	30.39	48	4.52	4.44	4.36	103	0.93	0.90	0.87
-2	30.35	29.72	29.11	49	4.38	4.30	4.22	104	0.91	0.87	0.84
-1	30.00	28.47	27.89	50	4.24	4.16	4.08	105	0.88	0.85	0.82
0	27.83	27.28	26.74	51	4.10	4.02	3.95	106	0.86	0.83	0.80
				52	3.97	3.90	3.82	107	0.84	0.81	0.78
				53	3.84	3.77	3.69	108	0.82	0.79	0.76
				54	3.72	3.65	3.57	109	0.80	0.77	0.74
				55	3.61	3.53	3.46	110	0.78	0.75	0.73

5. TECHNICAL SPECIFICATIONS

Power supply	from 9 to 30 Vdc 12 to 24 Vac tolerance -10%, +15%
Current input (0 to 1 V 4-20 mA and 0 to 10 V active outputs)	- voltage output, load 10kΩ, 2 outputs Vout max 10 mA @ 12 Vdc power supply 8 mA @ 24 Vdc power supply - current output, 2 x 20 mA outputs 35mA @ 12 Vdc power supply 24mA @ 24 Vdc power supply
AC power consumption (VA)	50mA @ 12 Vac power supply 24mA @ 24 Vac power supply 0.6 VA max power consumption / sensor
DC current input (RS485 serial output) (mA)	- <i>Direct serial version</i> typ. 5 – max 12 mA @ 12 Vdc power supply typ. 4 - max 8 mA @ 24 Vdc power supply - <i>Optically-isolated serial version, typ. - max</i> typ. 14 - max 20 mA @ 12 Vdc power supply typ. 9 – max 13 mA @ 24 Vdc power supply
AC power consumption (VA)	35 – 49mA RMS @ 12 Vac 25 – 33mA RMS @ 24 Vac 0.8 VA max power consumption / sensor
Operating range	<b>DPW sensors</b> Temperature: from -10 °C to +60 °C Humidity: from 10 to 90 % rH <b>DPD and DPP sensors</b> Temperature: from -20 °C to +70 °C Humidity: from 10 a 90 % rH and from 0 to 100 % rH, according to the model
Precision	<i>for DPW</i> the temperature range is: -10T60 °C NTC resistive: ±0.3°C at 25°C, ±0.5°C from 0°C to 50°C, ±0.7°C -20T70 °C Temperature outputs (*1): -0.5/1V 0/1V 0/10V and 4/20 mA ±0.5°C at 25°C, ±0.9°C -10T60 °C ±0.5°C at 25°C, ±0.9°C -20T70 °C Humidity outputs (*2): -0.5/1V 0/1V 0/10V and 4/20 mA, ±3% rH at 25°C/50% rH, ±5% rH -20T70 °C and 10-90 % rH ±2% rH at 25°C/50% rH, ±5% rH -20T70 °C and 0-100 % rH Temperature serial output (*1) ±0.5°C at 25°C, ±0.9°C -10T60 °C ±0.5°C at 25°C, +/-0.9°C -20T70 °C Humidity serial output (*2) ±3% rH at 25°C/50% rH, ±5% rH -10T60 °C and 10-90 % rH ±2% rH at 25°C/50% rH, ±5% rH -20T70 °C and 0-100 % rH (*1) Temperature: possible variations within ±2 °C in the presence of strong electromagnetic fields (10Vm) (*2) Humidity: possible errors within ±5 % rH in the presence of strong electromagnetic fields (10Vm)
Storage	-20T70 °C; 10-90% rH non-condensing
Operating limits	-10T60 °C; 10-90% rH non-condensing for DPW versions -20T70 °C; 0-100% rH non-condensing for DPD / DPP versions
Temperature sensor	NTC 10KΩ at 25°C 1%
Humidity sensor	Capacitive sensor

Humidity output signals	<p>Range 0 to 100% rH            Voltage 10 mV/% rH for 0 to 1V (load Rmin = 1 kΩ)            Voltage 100 mV/% rH for 0 to 10V (load Rmin = 1 kΩ)            Current 4 to 20 mA 4mA=0% rH; 20 mA=100% rH (load Rmax= 100 Ω)</p>
Temperature output signals	<p>Range -30T70 °C            Voltage 10 mV/% rH for -0.5 to 1V (load Rmin = 1 kΩ)            Voltage for 0 to 1V 0V = -30°C ; 1V =+70°C (load Rmin = 1 kΩ)            Voltage for 0 to 10V 0V = -30°C ; 10V =+70°C (load Rmin = 1 kΩ)            Current 4 to 20 mA 4 mA=-30°C ; 20 mA=+70°C (load Rmax= 100Ω)</p>
Terminal block	Screw terminals for cables max. cross-section 1.5 – min. 0.5 mm <sup>2</sup>
Case index of protection	IP55 for DPD, DPP (ducts and ind. env.) IP30 for DPW (wall)
Sensor index of protection	IP54 for DPP IP40 for DPD IP30 for DPW
Temperature time constant	in still air 300 s in moving air (3 m/s) 60 s
Humidity time constant	in still air 60 s in moving air (3 m/s) 20 s
Classification according to protection against electric shock	Can be integrated in class 1 and 2 equipment
PTI of the insulating materials	250 V
Period of stress across the insulating parts	Long
Environmental pollution	Normal
Category of resistance to heat and fire	Category D (for case and cover)
Category (immunity against voltage surges)	Category 2

## 5.1 Cleaning and maintenance

When cleaning the instrument do not use ethyl alcohol, hydrocarbons (petrol), ammonia and derivatives. Use neutral detergents and water. Periodically check the aeration slits on the sensor to make sure that air can flow freely through, without obstructions due to impurities or dust in the site of installation.

## 5.2 Disposal of the instrument.

The sensor is made up of plastic parts and metal parts. Do not dispose of the device as household waste! All the parts must be disposed of according to the local waste disposal legislation in force.



### IMPORTANT WARNINGS

The CAREL product is a state-of-the-art device, whose operation is specified in the technical documentation supplied with the product or can be downloaded, even prior to purchase, from the website [www.carel.com](http://www.carel.com). The customer (manufacturer, developer or installer of the final equipment) accepts all liability and risk relating to the configuration of the product in order to reach the expected results in relation to the specific final installation and/or equipment. The failure to complete such phase, which is required/indicated in the user manual, may cause the final product to malfunction; CAREL accepts no liability in such cases. The customer must use the product only in the manner described in the documentation relating to the product. The liability of CAREL in relation to its products is specified in the CAREL general contract conditions, available on the website [www.carel.com](http://www.carel.com) and/or by specific agreements with customers.

## 6. WARNINGS FOR THE REPLACEMENT OF THE AS\* SERIES

The size and fittings of the DP series\* sensors are compatible with the AS\* series. Specifically:  
model ASW is perfectly compatible with model DPW\*  
for model ASP\*, the outside dimensions and the drilling template are different than for model DPP\*.  
for model ASD\*, the outside dimensions are different, while the fastening flange remains unchanged for model DPD\*

For the 0 to 1 V, 0 to 10 V and 4 to 20 mA outputs, the start and end scale values are different from those on the AS\* series analogue sensors. For further information, see the chapter **Functional notes and differences between DP and AS sensors**.